

O-RING FACE SEAL FITTINGS



**Western Valve
& Fitting**

(925-443-8500)

4355 Technology Drive

Livermore, CA 94551

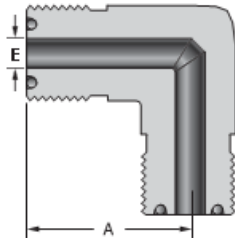
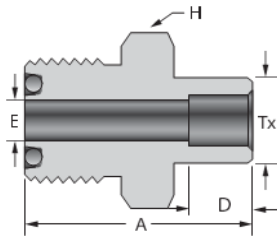
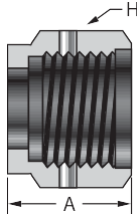

Table of Contents

| | |
|---------------------------|----------------------------------|
| Female Nuts | Page 2 |
| Blind Nuts | Page 2 |
| Union Fittings | Page 2, 5 |
| Connector Fittings | Page 2, 4, 5, 7, 8, 9, 10 |
| Gland Fittings | Page 2, 3, 4 |
| Elbow Fittings | Page 6, 8, 10 |
| Tee Fittings | Page 6 |
| Body Plugs | Page 6 |

Female Nut



| Part No. | Size | Dimensions, in. (mm) | |
|----------|-------------|----------------------|-------|
| | | A | H |
| SFVN-4 | 1/8 and 1/4 | 0.66 (16.8) | 11/16 |
| SFVN-8 | 3/8 and 1/2 | 0.69 (17.5) | 1 |
| SFVN-12 | 3/4 | 0.81 (20.6) | 1 1/2 |
| SFVN-16 | 1 | 0.81 (20.6) | 1 3/4 |

Blind Nut

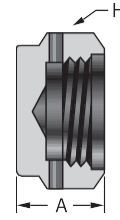

| Part No. | Size | Dimensions, in. (mm) | |
|----------|-------------|----------------------|-------|
| | | A | H |
| SFVN-4 | 1/8 and 1/4 | 0.44 (11.2) | 11/16 |
| SFVN-8 | 3/8 and 1/2 | 0.56 (14.2) | 1 |
| SFVN-12 | 3/4 | 0.75 (19.1) | 1 1/2 |
| SFVN-16 | 1 | 0.81 (20.6) | 1 3/4 |

Glands Swivel Union

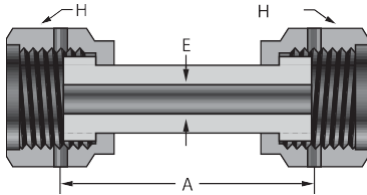

| Part No. | Size | Dimensions, in. (mm) | | | Pressure Rating Psig (bar) |
|----------|------|----------------------|----------------|-------|-------------------------------|
| | | A | E | H | |
| SGU-4 | 1/4 | 1.42 (36.1) | 0.18 (4.6) | 11/16 | 10 200 (702) |
| SGU-8 | 1/2 | 1.61 (40.9) | 0.40 (10.2) | 1 | 5 800 (399) |

Tube Fitting Connector

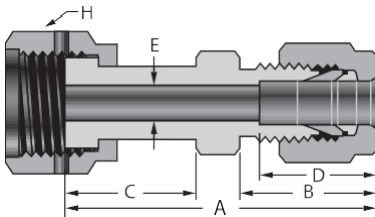

| Part No. | Size | Tube OD | Dimensions, in. (mm) | | | | | Pressure Rating Psig (bar) | |
|-------------|------|------------|----------------------|----------------|----------------|----------------|----------------|----------------------------------|-----------------|
| | | | A | B | C | D | E | | |
| STFC-4-4T | 1/4 | 1/4 | 1.74 (44.2) | 0.70 (17.8) | 0.77 (19.6) | 0.60 (15.2) | 0.18 (4.6) | 11/16 | 10 200 (702) |
| STFC-8-6T | 1/2 | 3/8 | 1.87 (47.5) | 0.76 (19.3) | 0.81 (20.6) | 0.66 (16.8) | 0.28 (7.1) | 1 | 5 800 (399) |
| STFC-8-8T | 1/2 | 1/2 | 2.01 (51.1) | 0.87 (22.1) | | 0.40 (10.2) | 0.40 (10.2) | | |
| STFC-12-12T | 3/4 | 3/4 | 2.14 (54.4) | 0.87 (22.1) | 0.94 (23.9) | 0.96 (24.4) | 0.62 (15.7) | 1 1/2 | 4 000 (275) |
| STFC-16-16T | 1 | 1 | 2.45 (62.2) | 1.04 (26.4) | 0.98 (24.9) | 1.23 (31.2) | 0.87 (22.1) | 1 3/4 | 3 000 (206) |

Tube Adapter Gland

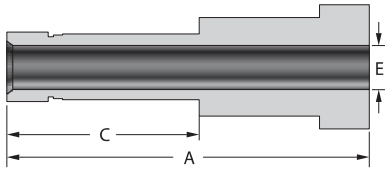

| Part No | Size | Tube OD | Dimensions, in. (mm) | | | Pressure Rating Psig (bar) |
|-------------|------|---------|----------------------|----------------|----------------|----------------------------|
| | | | A | C | E | |
| STAG-4-4T | 1/4 | 1/4 | 1.31 (33.3) | 0.64 (16.3) | 0.18 (4.6) | 10 200 (702) |
| STAG-8-6T | 1/2 | 3/8 | 1.38 (35.1) | 0.70 (17.8) | 0.27 (6.8) | 6 500 (447) |
| STAG-8-8T | 1/2 | 1/2 | 1.62 (41.1) | 0.96 (24.4) | 0.37 (9.3) | 6 700 (461) |
| STAG-12-12T | 3/4 | 3/4 | 1.80 (45.7) | 1.02 (25.9) | 0.58 (14.7) | 5 800 (399) |
| STAG-16-16T | 1 | 1 | 2.05 (52.1) | 1.30 (33.0) | 0.80 (20.3) | 4 700 (323) |

Weld Tube Socket Weld Gland

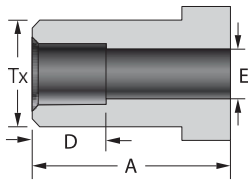

| Part No | Size | Tube OD | Dimensions, in. (mm) | | | | Pressure Rating Psig (bar) |
|-------------|------|---------|----------------------|----------------|----------------|----------------|----------------------------|
| | | | A | D | E | Tx | |
| STWG-2-2T | 1/8 | 1/8 | 0.77 (19.6) | 0.10 (2.5) | 0.09 (2.3) | 0.38 (9.7) | 15 400 (1061) |
| STWG-4-4T | 1/4 | 1/4 | 0.77 (19.6) | 0.28 (7.1) | 0.18 (4.6) | 0.38 (9.7) | 6 800 (468) |
| STWG-6-6T | 3/8 | 3/8 | 0.81 (20.6) | 0.31 (7.9) | 0.28 (7.1) | 0.60 (15.2) | 8 100 (558) |
| STWG-8-8T | 1/2 | 1/2 | 0.81 (20.6) | 0.38 (9.7) | 0.40 (10.2) | 0.60 (15.2) | 3 000 (206) |
| STWG-12-12T | 3/4 | 3/4 | 0.94 (23.9) | 0.44 (11.2) | 0.62 (15.7) | 0.92 (23.4) | 3 700 (255) |
| STWG-16-16T | 1 | 1 | 0.98 (24.9) | 0.62 (15.7) | 0.87 (22.1) | 1.19 (30.2) | 3 000 (206) |

Tube Socket Weld Reducing Gland

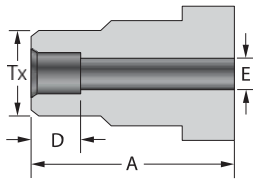

| Part No | Size | Tube OD | Dimensions, in. (mm) | | | | Pressure Rating Psig (bar) |
|-----------|------|---------|----------------------|---------------|---------------|----------------|----------------------------|
| | | | A | D | E | Tx | |
| STRG-4-2T | 1/4 | 1/8 | 0.77 (19.6) | 0.10 (2.5) | 0.09 (2.3) | 0.29 (7.4) | 12 600 (868) |
| STRG-8-4T | 1/2 | 1/4 | 0.81 (20.6) | 0.28 (7.1) | 0.18 (4.6) | 0.48 (12.2) | 10 700 (737) |

Male Tube Weld Gland

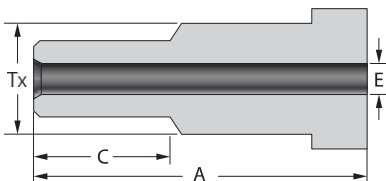

| Part No | Size | Tube OD | Dimensions, in. (mm) | | | | Pressure Rating Psig (bar) |
|-----------|------|---------|----------------------|----------------|----------------|----------------|----------------------------|
| | | | A | D | E | Tx | |
| SMWG-4-2T | 1/4 | 1/8 | 0.77 (19.6) | 0.10 (2.5) | 0.09 (2.3) | 0.38 (9.7) | 15 400 (1061) |
| SMWG-4-4T | | 1/4 | 0.77 (19.6) | 0.28 (7.1) | 0.18 (4.6) | 0.38 (9.7) | 6 800 (468) |
| SMWG-8-4T | 1/2 | 1/4 | 0.81 (20.6) | 0.31 (7.9) | 0.28 (7.1) | 0.60 (15.2) | 8 100 (558) |
| SMWG-8-6T | | 3/8 | 0.81 (20.6) | 0.38 (9.7) | 0.40 (10.2) | 0.60 (15.2) | 3 000 (206) |
| SMWG-8-8T | | 1/2 | 0.98 (24.9) | 0.62 (15.7) | 0.87 (22.1) | 1.19 (30.2) | 3 000 (206) |

Automatic Tube Weld Gland

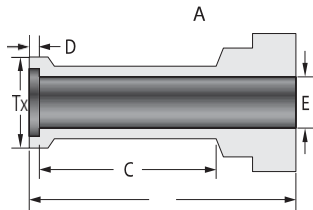

| Part No | Size | Tube OD | Dimensions, in. (mm) | | | | | Wall Thickness | Pressure Rating Psig (bar) |
|-------------|------|---------|----------------------|----------------|----------------|----------------|----------------|----------------|----------------------------|
| | | | A | C | D | E | Tx | | |
| SATG-4-4T | 1/4 | 1/4 | 1.12 (28.4) | 0.78 (19.8) | 0.02 (0.51) | 0.18 (4.6) | 0.29 (7.4) | 0.035 | 5 100 (351) |
| SATG-8-6T | 1/2 | 3/8 | 1.13 (28.7) | 0.79 (20.0) | 0.03 (0.76) | 0.31 (7.9) | 0.41 (10.4) | 0.035 | 3 300 (227) |
| SATG-8-8T | 1/2 | 1/2 | 1.14 (29.0) | 0.80 (20.3) | 0.04 (1.0) | 0.40 (10.2) | 0.55 (14.0) | 0.049 | 3 500 (241) |
| SATG-12-12T | 3/4 | 3/4 | 1.20 (30.5) | 0.80 (20.3) | 0.04 (1.0) | 0.65 (16.5) | 0.80 (20.3) | 0.049 | 2 200 (151) |
| SATG-16-16T | 1 | 1 | 1.41 (35.8) | 1.00 (25.4) | 0.04 (1.0) | 0.87 (22.1) | 1.06 (26.9) | 0.065 | 2 200 (151) |

Male Connector

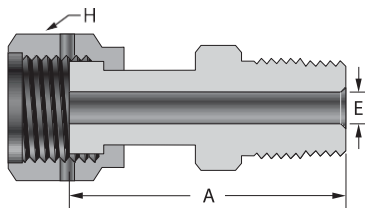

| Part No | Size | Tube OD | Dimensions, in. (mm) | | | Pressure Rating Psig (bar) |
|-------------|------|---------|----------------------|----------------|-------|----------------------------|
| | | | A | E | H | |
| SRMC-4-4N | 1/4 | 1/4 | 1.59 (40.4) | 0.18 (4.6) | 11/16 | 9 800 (675) |
| SRMC-8-6N | 1/2 | 3/8 | 1.67 (42.4) | 0.40 (10.2) | 1 | 5 600 (385) |
| SRMC-8-8N | 1/2 | 1/2 | 1.87 (47.5) | 0.40 (10.2) | 1 | 5 600 (385) |
| SRMC-12-12N | 3/4 | 3/4 | 2.03 (51.6) | 0.62 (15.7) | 1 1/2 | 3 900 (268) |
| SRMC-16-16N | 1 | 1 | 2.36 (59.9) | 0.87 (22.1) | 1 3/4 | 2 900 (199) |

Female Connector

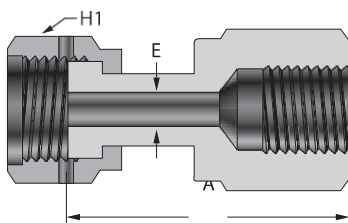

| Part No | Size | NPT Size | Dimensions, in. (mm) | | | | Pressure Rating Psig (bar) |
|------------|------|----------|----------------------|----------------|--------|-------|----------------------------|
| | | | A | E | H | H1 | |
| SFC-4-4N | 1/4 | 1/4 | 1.57 (39.9) | 0.18 (4.6) | 3/4 | 11/16 | 6 600 (454) |
| SFC-8-6N | 1/2 | 3/8 | 1.73 (43.9) | 0.40 (10.2) | 7/8 | 1 | 5 300 (365) |
| SFC-8-8N | 1/2 | 1/2 | 1.96 (49.8) | 0.40 (10.2) | 1 1/16 | 1 | 4 900 (337) |
| SFC-12-12N | 3/4 | 3/4 | 2.12 (53.8) | 0.62 (15.7) | 1 5/16 | 1 1/2 | 4 000 (275) |
| SFC-16-16N | 1 | 1 | 2.29 (58.2) | 0.87 (22.1) | 1 5/8 | 1 3/4 | 3 000 (206) |

Male SAE/MS Connector

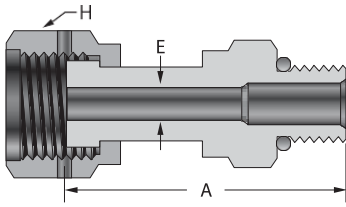

| Part No | Size | Thread Size | Dimensions, in. (mm) | | | Pressure Rating Psig (bar) |
|-------------|------|-------------|----------------------|----------------|-------|-------------------------------|
| | | | A | E | H | |
| SMSC-4-4U | 1/4 | 7/16-20 | 1.54 (39.1) | 0.18 (4.6) | 11/16 | 4 500 (310) |
| SMSC-8-6U | 1/2 | 9/16-18 | 1.64 (41.7) | 0.40 (10.2) | 1 | 4 500 (310) |
| SMSC-8-8U | 1/2 | 3/4-16 | 1.71 (43.4) | 0.40 (10.2) | 1 | 4 500 (310) |
| SMSC-12-12U | 3/4 | 1 1/16-12 | 2.07 (52.6) | 0.62 (15.7) | 1 1/2 | 3 600 (248) |
| SMSC-16-16U | 1 | 1 5/16-12 | 2.17 (55.1) | 0.87 (22.1) | 1 3/4 | 2 900 (199) |

Union

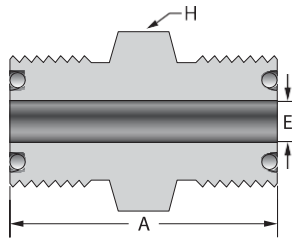

| Part No | Size | Dimensions, in. (mm) | | | Pressure Rating Psig (bar) |
|---------|------|----------------------|---------------|-------|-------------------------------|
| | | A | E | H | |
| SU-4 | 1/4 | 1.25 (31.8) | 0.18 (4.6) | 5/8 | 14 300 (985) |
| SU-8 | 1/2 | 1.50 (38.1) | 0.40 (10.2) | 15/16 | 11 100 (764) |

Bulkhead Union

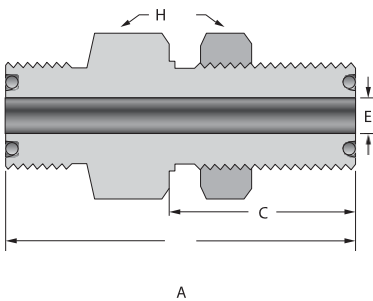

| Part No | Size | Dimensions, in. (mm) | | | | | Pressure Rating Psig (bar) | |
|---------|------|----------------------|----------------|----------------|--------|-----------------------|-------------------------------|-----------------|
| | | A | C | E | H | Panel Hole Drill Size | | |
| SBU-4 | 1/4 | 1.88 (47.8) | 1.06 (26.9) | 0.18 (4.6) | 3/4 | 37/64 | 0.36 (9.1) | 14 300 (985) |
| SBU-8 | 1/2 | 2.09 (53.1) | 1.19 (30.2) | 0.40 (10.2) | 1 1/16 | 57/64 | 0.40 (10.2) | 11 100 (764) |

Reducing Union

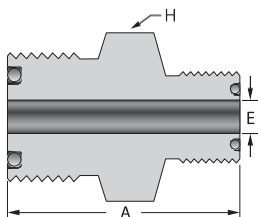

| Part No | Size | Size | Dimensions, in. (mm) | | | Pressure Rating Psig (bar) |
|---------|------|------|----------------------|---------------|-------|-------------------------------|
| | | | A | E | H | |
| SRU-4 | 1/2 | 1/4 | 1.43 (36.3) | 0.18 (4.6) | 15/16 | 11 100 (764) |

Elbow

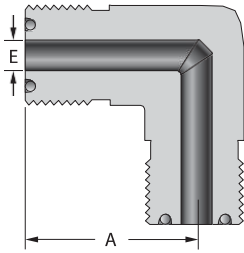

| Part No | Size | Dimensions, in. (mm) | | Pressure Rating Psig (bar) |
|---------|------|----------------------|----------------|----------------------------|
| | | A | E | |
| SEU-4 | 1/4 | 0.96 (24.4) | 0.18 (4.6) | 14 300 (985) |
| SEU-8 | 1/2 | 1.26 (32.0) | 0.40 (10.2) | 11 100 |
| SEU-12 | 3/4 | 1.48 (37.6) | 0.62 (15.7) | 10 900 (751) |
| SEU-16 | 1 | 1.56 (39.6) | 0.87 (22.1) | 8 800 (606) |

Tee

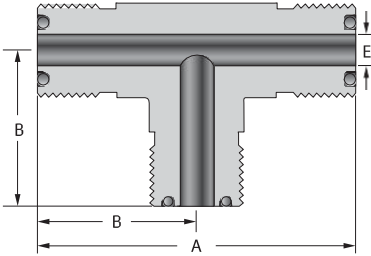

| Part No | Size | Dimensions, in. (mm) | | | Pressure Rating Psig (bar) |
|---------|------|----------------------|----------------|----------------|----------------------------|
| | | A | B | E | |
| ST-4 | 1/4 | 1.92 (48.8) | 0.96 (24.4) | 0.18 (4.6) | 14 300 (985) |
| ST-8 | 1/2 | 2.52 (64.0) | 1.26 (32.0) | 0.40 (10.2) | 11 100 (764) |
| ST-12 | 3/4 | 2.96 (75.2) | 1.48 (37.6) | 0.62 (15.7) | 10 900 (751) |
| ST-16 | 1 | 3.12 (79.2) | 1.56 (39.6) | 0.87 (22.1) | 8 800 (606) |

Body Plugs

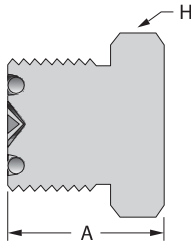

| Part No | DO Size | Dimensions, in. (mm) | |
|---------|---------|----------------------|--------|
| | | A | H |
| SBP-4 | 1/4 | 0.77 (19.6) | 5/8 |
| SBP-8 | 1/2 | 0.89 (22.6) | 15/16 |
| SBP-12 | 3/4 | 0.99 (25.1) | 1 5/16 |
| SBP-16 | 1 | 1.02 (25.9) | 1 5/8 |

Tube Fitting Connector

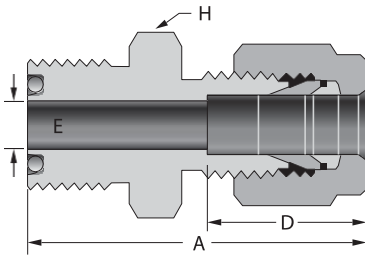

| Part No | Size | Tube OD | Dimensions, in. (mm) | | | | Pressure Rating Psig (bar) |
|-------------|------|---------|----------------------|----------------|----------------|--------|-------------------------------|
| | | | A | D | E | H | |
| STFC-4-2T | 1/4 | 1/8 | 1.38 (35.1) | 0.51 (13.0) | 0.09 (2.3) | 5/8 | 10 900 (751) |
| STFC-4-4T | 1/4 | 1/4 | 1.47 (37.3) | 0.60 (15.2) | 0.18 (4.6) | 5/8 | 10 200 (702) |
| STFC-8-6T | 1/2 | 3/8 | 1.65 (41.9) | 0.66 (16.8) | 0.28 (7.1) | 15/16 | 6 500 (447) |
| STFC-8-8T | 1/2 | 1/2 | 1.78 (45.2) | 0.90 (22.9) | 0.40 (10.2) | 15/16 | 6 700 (461) |
| STFC-12-12T | 3/4 | 3/4 | 1.86 (47.2) | 0.96 (24.4) | 0.62 (15.7) | 1 5/16 | 5 800 (399) |
| STFC-16-16T | 1 | 1 | 2.06 (52.3) | 1.23 (31.2) | 0.87 (22.1) | 1 5/8 | 4 700 (323) |

Tube Fitting Bulkhead Connector

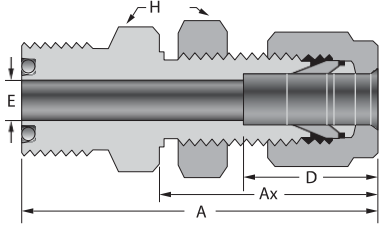

| Part No | Size | Tube OD | Dimensions, in. (mm) | | | | | Pane Hole Drill Size | Max Panel Thickness | Pressure Rating Psig (bar) |
|-------------|------|---------|----------------------|----------------|----------------|----------------|--------|----------------------|---------------------|----------------------------|
| | | | A | Ax | D | E | H | | | |
| STBC-4-4T | 1/4 | 1/4 | 2.10 (53.3) | 1.32 (33.5) | 0.60 (15.2) | 0.18 (4.6) | 5/8 | 29/64 | 0.40 (10.2) | 10 200 (702) |
| STBC-8-6T | 1/2 | 3/8 | 2.34 (59.4) | 1.45 (36.8) | 0.66 (16.8) | 0.28 (7.1) | 15/16 | 37/64 | 0.44 (11.2) | 6 500 (447) |
| STBC-8-8T | 1/2 | 1/2 | 2.55 (64.8) | 1.65 (41.9) | 0.90 (22.9) | 0.40 (10.2) | 15/16 | 49/64 | 0.50 (12.7) | 6 700 (461) |
| STBC-12-12T | 3/4 | 3/4 | 2.86 (72.6) | 1.87 (47.5) | 0.96 (24.4) | 0.62 (15.7) | 1 5/16 | 1 1/64 | 0.66 (16.8) | 5 800 (399) |
| STBC-16-16T | 1 | 1 | 3.29 (83.6) | 2.26 (57.4) | 1.23 (31.2) | 0.87 (22.1) | 1 5/8 | 1 21/64 | 0.75 (19.1) | 4 700 (323) |

Tube Fitting Elbow

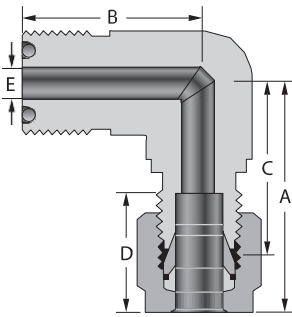

| Part No | Size | Tube OD | Dimensions, in. (mm) | | | | | Pressure Rating Psig (bar) |
|-------------|------|---------|----------------------|----------------|----------------|----------------|----------------|----------------------------|
| | | | A | B | C | D | E | |
| STFE-4-4T | 1/4 | 1/4 | 1.19 (30.2) | 0.96 (24.4) | 0.90 (22.9) | 0.60 (15.2) | 0.18 (4.6) | 10 200 (702) |
| STFE-8-6T | 1/2 | 3/8 | 1.39 (35.3) | 1.26 (32.0) | 1.10 (27.9) | 0.66 (16.8) | 0.28 (7.1) | 6 500 (447) |
| STFE-8-8T | 1/2 | 1/2 | 1.50 (38.1) | 1.26 (32.0) | 1.10 (27.9) | 0.90 (22.9) | 0.40 (10.2) | 6 700 (461) |
| STFE-12-12T | 3/4 | 3/4 | 1.80 (45.7) | 1.48 (37.6) | 1.40 (35.6) | 0.96 (24.4) | 0.62 (15.7) | 5 800 (399) |
| STFE-16-16T | 1 | 1 | 2.04 (51.8) | 1.56 (39.6) | 1.56 (31.2) | 1.23 (31.2) | 0.87 (22.1) | 4 700 (323) |

Bodies Tube Socket Weld Connector

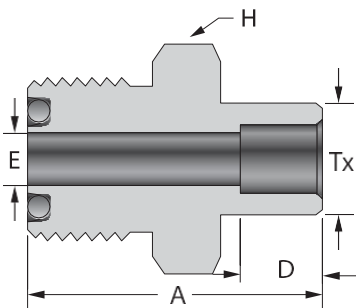

| Part No | Size | Tube OD | Dimensions, in. (mm) | | | | | Pressure Rating Psig (bar) |
|-------------|------|---------|----------------------|----------------|----------------|--------|----------------|----------------------------|
| | | | A | D | E | H | Tx | |
| SBTC-2-2T | 1/8 | 1/8 | 0.88 (22.4) | 0.10 (2.5) | 0.09 (2.3) | 5/8 | 0.29 (7.4) | 12 600 (868) |
| SBTC-4-4T | 1/4 | 1/4 | 1.09 (27.7) | 0.28 (7.1) | 0.18 (4.6) | 5/8 | 0.38 (9.7) | 6 800 (468) |
| SBTC-6-6T | 3/8 | 3/8 | 12.8 (32.5) | 0.31 (7.9) | 0.28 (7.1) | 15/16 | 0.60 (15.2) | 8 100 (558) |
| SBTC-8-8T | 1/2 | 1/2 | 1.34 (34.0) | 0.38 (9.7) | 0.40 (10.2) | 15/16 | 0.60 (15.2) | 3 000 (206) |
| SBTC-12-12T | 3/4 | 3/4 | 1.50 (38.1) | 0.44 (11.2) | 0.62 (15.7) | 1 5/16 | 0.92 (23.4) | 3 700 (255) |
| SBTC-16-16T | 1 | 1 | 1.72 (43.7) | 0.62 (15.7) | 0.87 (22.1) | 1 5/8 | 1.19 (30.2) | 3 000 (206) |

Automatic Tube Weld Connector

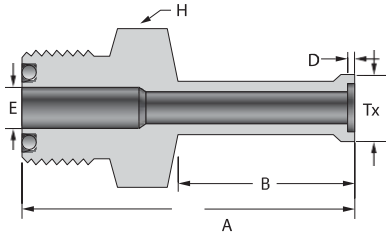

| Part No | Size | Tube OD | Dimensions, in. (mm) | | | | | | | Pressure Rating Psig (bar) |
|-------------|------|---------|----------------------|----------------|---------------|----------------|-------|----------------|-------|----------------------------|
| | | | A | B | D | E | H | Tx | Wall | |
| SATC-4-4T | 1/4 | 1/4 | 1.59 (40.4) | 0.78 (19.8) | 0.02 (0.5) | 0.18 (4.6) | 5/8 | 0.29 (7.4) | 0.035 | 5 100 (351) |
| SATC-6-6T | 3/8 | 3/8 | 1.74 (44.2) | 0.79 (20.0) | 0.03 (0.8) | 0.31 (7.9) | 15/16 | 0.41 (10.4) | 0.035 | 3 300 (227) |
| SATC-8-8T | 1/2 | 1/2 | 1.75 (44.4) | 0.80 (20.3) | 0.04 (1.0) | 0.40 (10.2) | 15/16 | 0.55 (14.0) | 0.049 | 3 500 (241) |
| SATC-12-12T | 3/4 | 3/4 | 1.78 (45.2) | 0.80 (20.3) | 0.04 (1.0) | 0.65 (16.5) | 15/16 | 0.80 (20.3) | 0.049 | 2 200 (151) |
| SATC-16-16T | 1 | 1 | 2.03 (51.6) | 1.00 (25.4) | 0.04 (1.0) | 0.87 (22.1) | 15/8 | 1.06 (26.9) | 0.065 | 2 200 (151) |

Male Connector

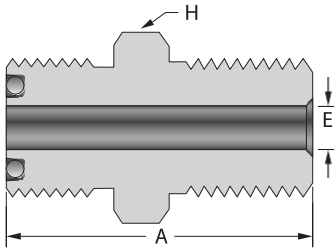

| Part No | Size | Male NPT | Dimensions, in. (mm) | | | Pressure Rating Psig (bar) |
|------------|------|----------|----------------------|----------------|--------|----------------------------|
| | | | A | E | H | |
| SMC-4-2N | 1/4 | 1/8 | 1.16 (29.5) | 0.18 (4.6) | 5/8 | 10 000 (689) |
| SMC-4-4N | 1/4 | 1/4 | 1.34 (34.0) | 0.18 (4.6) | 5/8 | 13 400 (923) |
| SMC-8-6N | 1/2 | 3/8 | 1.46 (37.1) | 0.38 (9.7) | 15/16 | 7 800 (537) |
| SMC-8-8N | 1/2 | 1/2 | 1.65 (41.9) | 0.40 (10.2) | 15/16 | 10 000 (689) |
| SMC-12-12N | 3/4 | 3/4 | 1.75 (44.4) | 0.62 (15.7) | 1 5/16 | 7 300 (502) |
| SMC-16-16N | 1 | 1 | 1.97 (50.0) | 0.87 (22.1) | 1 5/8 | 5 300 (365) |

Bodies Female Connector

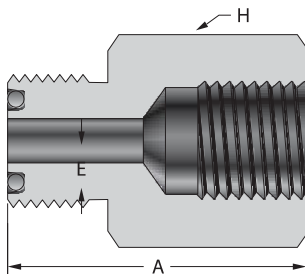

| Part No | Size | Male NPT | Dimensions, in. (mm) | | | Pressure Rating Psig (bar) |
|------------|------|----------|----------------------|----------------|--------|----------------------------|
| | | | A | E | H | |
| SFC-4-2N | 1/4 | 1/8 | 1.25 (31.8) | 0.18 (4.6) | 5/8 | 8 400 (578) |
| SFC-4-4N | 1/4 | 1/4 | 1.39 (35.3) | 0.18 (4.6) | 3/4 | 6 600 (454) |
| SFC-8-6N | 1/2 | 3/8 | 1.57 (39.9) | 0.40 (10.2) | 15/16 | 6 600 (454) |
| SFC-8-8N | 1/2 | 1/2 | 1.77 (45.0) | 0.40 (10.2) | 1 1/16 | 4 900 (337) |
| SFC-12-12N | 3/4 | 3/4 | 1.93 (49.0) | 0.62 (15.7) | 1 5/16 | 4 600 (316) |
| SFC-16-16N | 1 | 1 | 2.02 (51.3) | 0.87 (22.1) | 1 5/8 | 4 400 (303) |

Male Elbow

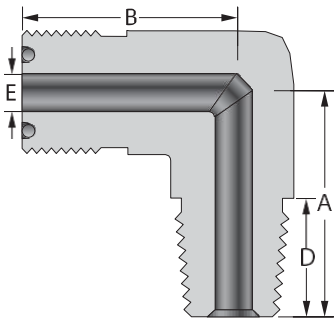

| Part No | Size | Male NPT | Dimensions, in. (mm) | | | | Pressure Rating Psig (bar) |
|------------|------|----------|----------------------|----------------|----------------|----------------|----------------------------|
| | | | A | B | D | E | |
| SEP-4-2N | 1/4 | 1/8 | 0.87 (22.1) | 0.96 (24.4) | 0.38 (9.7) | 0.18 (4.6) | 10 000 (689) |
| SEP-4-4N | 1/4 | 1/4 | 1.05 (26.7) | 0.96 (24.4) | 0.56 (14.2) | 0.18 (4.6) | 8 000 (551) |
| SEP-8-6N | 1/2 | 3/8 | 1.26 (32.0) | 1.26 (32.0) | 0.56 (14.2) | 0.38 (9.7) | 7 800 (537) |
| SEP-8-8N | 1/2 | 1/2 | 1.45 (36.8) | 1.26 (32.0) | 0.75 (19.1) | 0.40 (10.2) | 7 700 (530) |
| SEP-12-12N | 3/4 | 3/4 | 1.67 (42.4) | 1.48 (37.6) | 0.75 (19.1) | 0.62 (15.7) | 7 300 (502) |
| SEP-16-16N | 1 | 1 | 1.94 (49.3) | 1.56 (39.6) | 0.94 (23.9) | 0.87 (22.1) | 5 300 (365) |

Male SAE / MS Connector

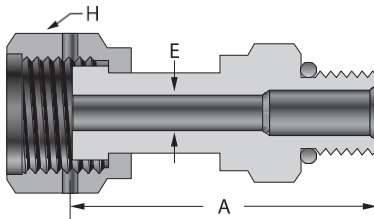

| Part No | Size | Straight Thread | Dimensions, in. (mm) | | | | Pressure Rating Psig (bar) |
|-------------|------|-----------------|----------------------|----------------|----------------|-------|----------------------------|
| | | | A | C | E | H | |
| SMSC-4-4U | 1/4 | 7/16-20 | 1.24 (31.5) | 0.36 (9.1) | 0.18 (4.6) | 11/16 | 4 500 (310) |
| SMSC-4-6U | 1/4 | 9/16-18 | 1.17 (29.7) | 0.39 (9.9) | 0.18 (4.6) | 11/16 | |
| SMSC-8-4U | 1/2 | 7/16-20 | 1.36 (34.5) | 0.36 (9.1) | 0.18 (4.6) | 1 1/2 | 4 500 (310) |
| SMSC-8-6U | 1/2 | 9/16-18 | 1.39 (35.3) | 0.39 (9.9) | 0.30 (7.7) | 1 1/2 | |
| SMSC-8-8U | 1/2 | 3/4-16 | 1.47 (37.3) | 0.40 (11.2) | 0.40 (10.2) | 1 | |
| SMSC-12-12U | 3/4 | 1 1/16-12 | 1.73 (43.9) | 0.59 (15.0) | 0.62 (15.7) | 1 3/8 | 3 600 (248) |
| SMSC-16-16U | 1 | 1 5/16-12 | 1.79 (45.5) | 0.59 (15.0) | 0.85 (21.6) | 1 5/8 | 2 900 (199) |

Male SAE / MS Positionable Elbow

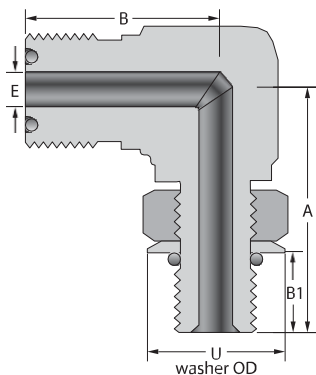

| Part No | Size | Straight Thread | Dimensions, in. (mm) | | | | | Pressure Rating Psig (bar) |
|----------------|------|-----------------|----------------------|----------------|----------------|----------------|----------------|----------------------------|
| | | | A | B | B1 | E | U | |
| SDOR-4-4-SAE | 1/4 | 7/16-20 | 1.19 (30.2) | 0.96 (24.4) | 0.39 (9.9) | 0.19 (4.6) | 0.65 (16.5) | 4 500 (310) |
| SDOR-8-6-SAE | 1/2 | 9/16-18 | 1.54 (39.1) | 1.33 (33.8) | 0.44 (11.2) | 0.30 (7.6) | 0.79 (20.1) | 3 600 (248) |
| SDOR-8-8-SAE | 1/2 | 3/4-16 | 1.65 (41.9) | 1.33 (33.8) | 0.50 (12.7) | 0.40 (10.2) | 1.01 (25.7) | |
| SDOR-12-12-SAE | 3/4 | 1 1/16-12 | 2.13 (54.1) | 1.53 (38.9) | 0.66 (16.8) | 0.62 (15.7) | 1.44 (36.6) | 2 900 (199) |
| SDOR-16-16-SAE | 1 | 1 5/16-12 | 2.31 (58.7) | 1.72 (43.7) | 0.66 (16.8) | 0.87 (22.1) | 1.73 (43.9) | 2 300 (158) |